

TRANSFER ASSY OVERHAUL

HINT:

COMPONENTS : See page [31-6](#)

1. DRAIN TRANSFER OIL

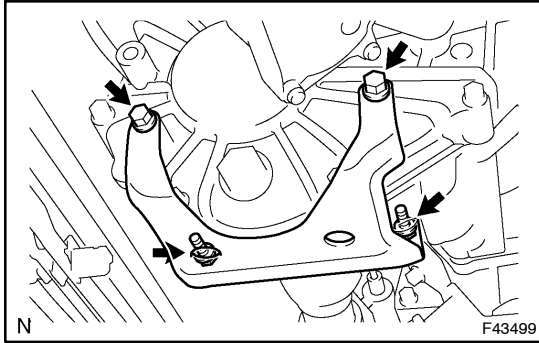

- 2. REMOVE TRANSFER CASE LOWER PROTECTOR**
(a) Remove the 4 bolts and transfer case lower protector.

3. REMOVE AUTOMATIC TRANSMISSION ASSY

- (a) 2UZ-FE : (See page [40-7](#))

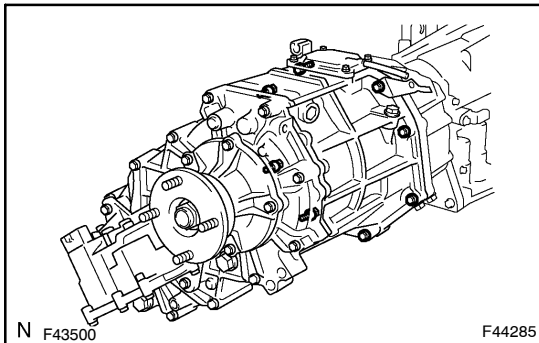

- 4. REMOVE TRANSFER ASSY**
(a) Remove the 8 bolts and 2 clamps from the transmission.

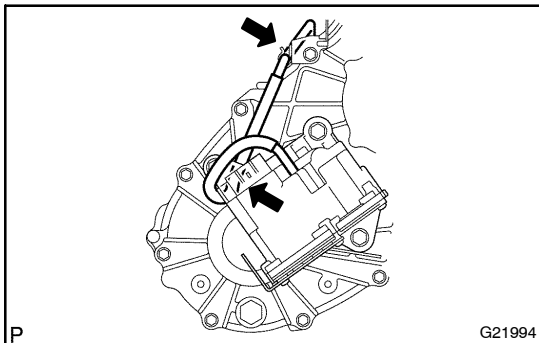

- 5. REMOVE HOSES**
(a) Remove a actuator motor breather hose.

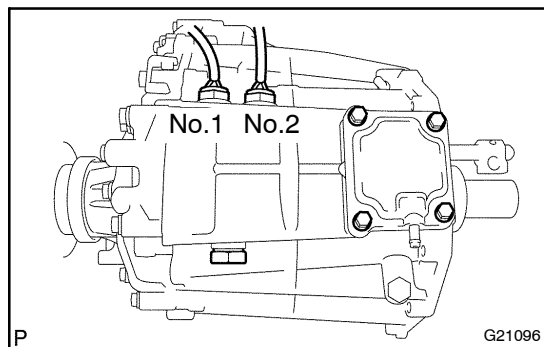
**6. REMOVE SWITCH**

- (a) Remove the indicator No.1 and No.2 switches, case No.1 plug and gaskets.

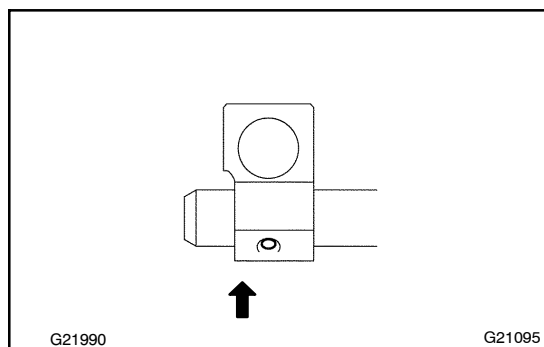
**7. REMOVE TRANSFER GEAR SHIFT HEAD NO.2**

- (a) Using a pin punch and hammer, remove the slotted pin from the gear shift head No.2.

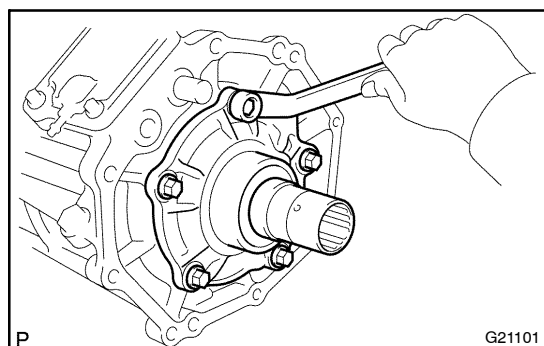
**8. REMOVE TRANSFER RH BEARING RETAINER SUB-ASSY**

- (a) Remove the 5 bolts and the bearing retainer sub-assy.
HINT:
 If necessary, tap the extension housing with a plastic hammer to remove it.

9. REMOVE TRANSFER COVER TYPE T OIL SEAL

- (a) Using a screwdriver and hammer, remove the oil seal from the bearing retainer sub-assy.

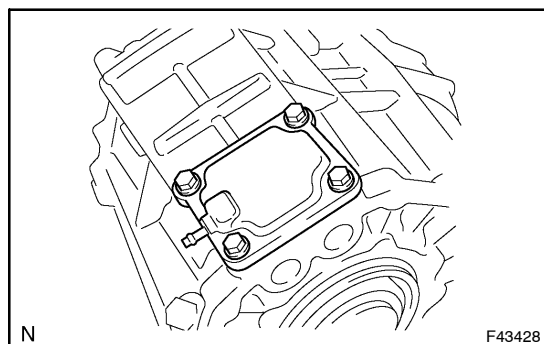
**10. REMOVE TRANSFER CASE COVER SUB-ASSY**

- (a) Remove the 4 bolts and case cover sub-assy.

11. REMOVE BREATHER OIL DEFLECTOR

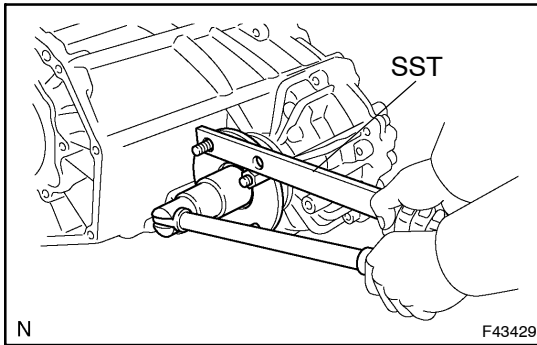

12. REMOVE OUTPUT SHAFT COMPANION FLANGE SUB-ASSY

- (a) Using a chisel and hammer, loosen the staked part of the output shaft companion flange lock nut.(front)
- (b) Using SST to hold the output shaft companion flange, remove the output shaft companion flange lock nut.(front)
SST 09330-00021

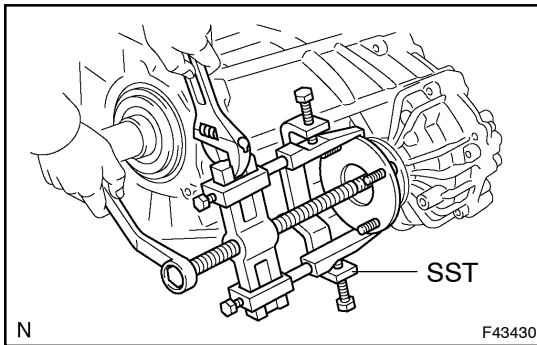

- (c) Using SST, remove the output shaft companion flange sub-assy.(front)
SST 09950-40011 (09951-04020, 09952-04010, 09953-04030, 09954-04010, 09955-04051, 09957-04010, 09958-04011)

13. REMOVE TRANSFER OUTPUT SHAFT COMPANION FLANGE OIL SEAL

- (a) Using a screwdriver and hammer, remove the oil seal from the output shaft companion flange sub-assy.(front)

14. REMOVE OUTPUT SHAFT COMPANION FLANGE SUB-ASSY

- (a) Remove the rear output shaft companion flange sub-assy in the same way as the front output shaft companion flange sub-assy.(rear)
SST 09330-00021, 09950-40011 (09951-04020, 09952-04010, 09953-04030, 09954-04010, 09955-04051, 09957-04010, 09958-04011)

15. REMOVE TRANSFER OUTPUT SHAFT COMPANION FLANGE OIL SEAL

- (a) Using a screwdriver and hammer, remove the oil seal from the rear output shaft companion flange sub-assy.(rear)

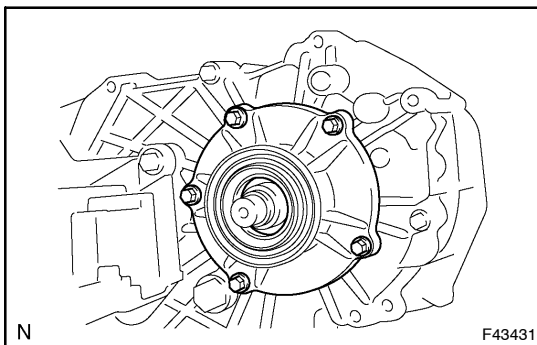

16. REMOVE EXTENSION HOUSING ASSY

- (a) Remove the 5 bolts and extension housing assy.

HINT:

If necessary, tap the extension housing assy rear with a plastic hammer to remove it.

17. REMOVE TRANSFER EXTENSION HOUSING TYPE T OIL SEAL

- (a) Using a screwdriver and hammer, remove the oil seal.

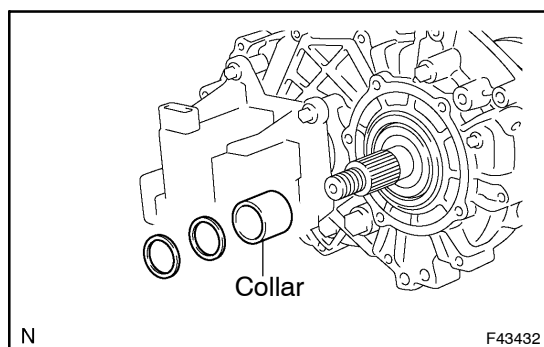
**18. REMOVE TRANSFER OUTPUT WASHER**

- (a) Remove the 2 output washer and collar.

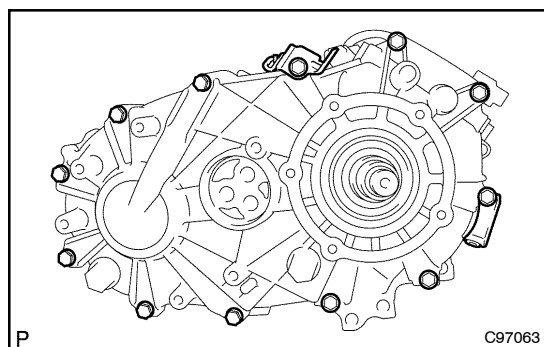
**19. REMOVE TRANSFER CASE REAR**

- (a) Remove the 12 bolts and 2 clamps.
 (b) Remove the transfer case rear.

HINT:

If necessary, tap the transfer case rear with a plastic hammer to remove it.

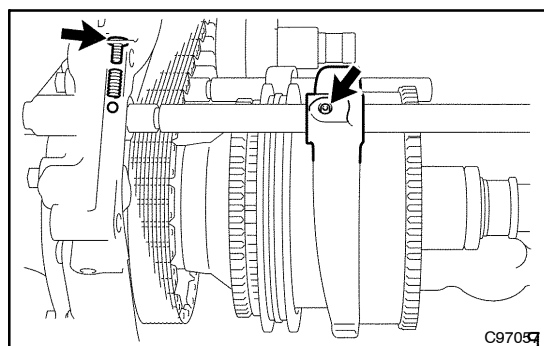
**20. REMOVE TRANSFER GEAR SHIFT FORK NO.2 W/TRANSFER HIGH AND LOW CLUTCH SLEEVE**

- (a) Using a hexagon wrench, remove the plug No.1.
 (b) Using a magnetic finger, remove the spring and ball from the hole.
 (c) Using a pin punch and hammer, drive out the slotted spring pin.
 (d) Remove the gear shift fork No.2 and high and low shift fork shaft.
 (e) Remove the high and low clutch sleeve.

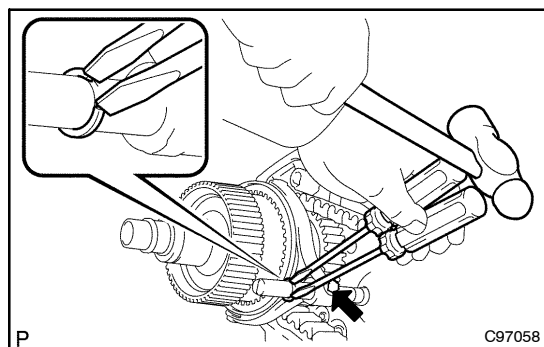
**21. REMOVE CTR DIFFERENTIAL LOCK FORK SUB-ASSY W/FRONT DRIVE CLUTCH SLEEVE**

- (a) Using 2 screwdrivers and a hammer, tap out the snap ring.

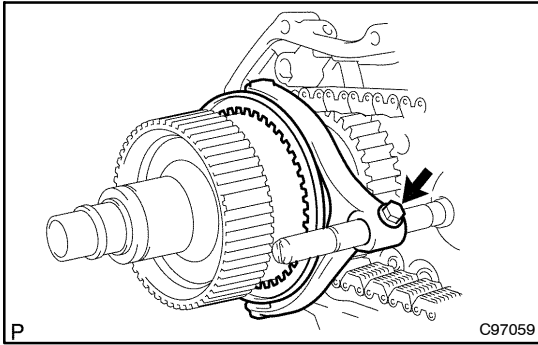

- (b) Remove the bolt, CTR differential lock fork sub-assy and front drive clutch sleeve.

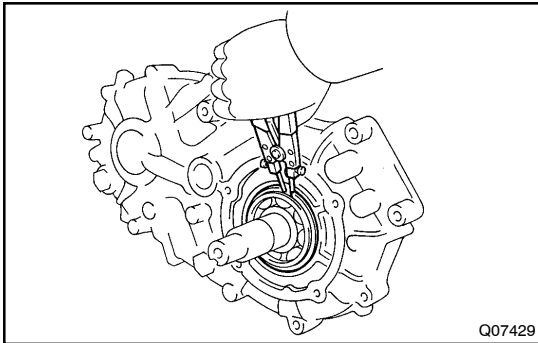

22. REMOVE REAR OUTPUT SHAFT SUB-ASSY, FRONT DRIVE CHAIN AND DRIVEN SPROCKET SUB-ASSY

- (a) Using a snap ring expander, remove the snap ring.
 (b) Mount the transfer case rear in a vise.

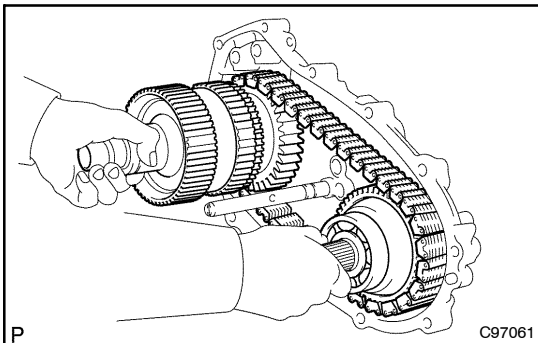

- (c) Using a plastic hammer, carefully tap the transfer case rear, and remove the rear output shaft sub-assy together with front drive chain and driven sprocket sub-assy.

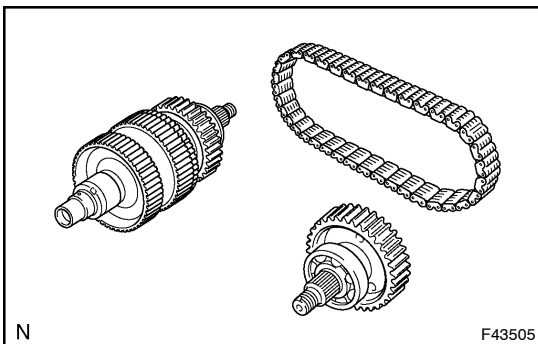

- (d) Remove the rear output shaft sub-assy, front drive chain and driven sprocket sub-assy.

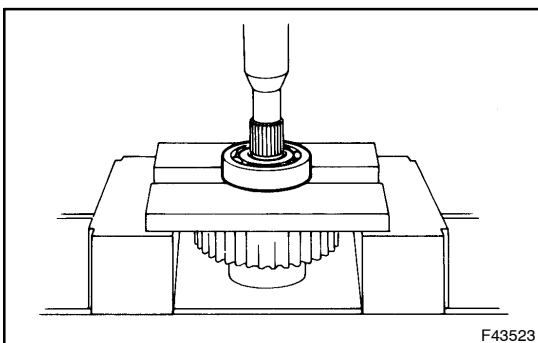

23. REMOVE TRANSFER DRIVEN SPROCKET BEARING

- (a) Using a press, remove the driven sprocket bearing.

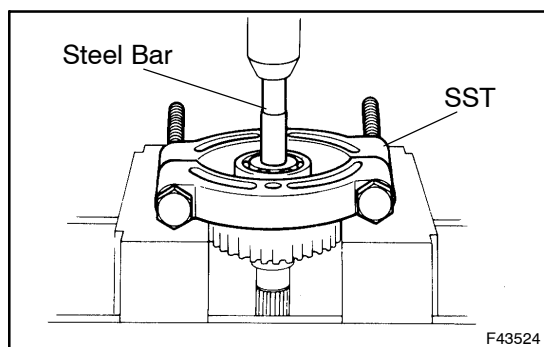

24. REMOVE TRANSFER INPUT GEAR RADIAL BALL BEARING

- (a) Using SST, a press and steel bar, remove the transfer input gear radial ball bearing.
SST 09555-55010

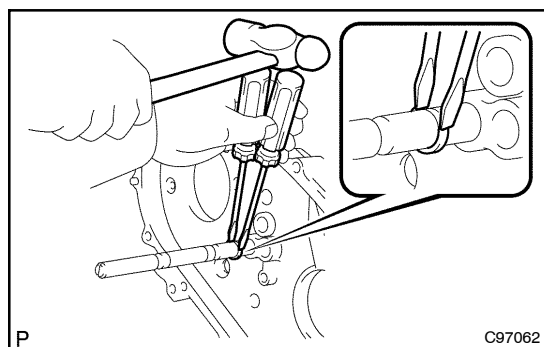

25. REMOVE TRANSFER SHIFT ACTUATOR ASSY

- (a) Using 2 screwdrivers and a hammer, tap out the snap ring.

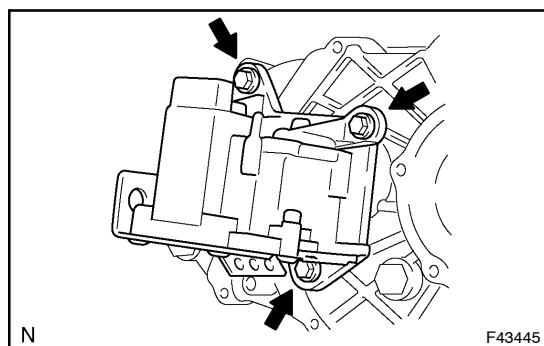

- (b) Remove the 3 bolts and transfer shift actuator assy.

26. REMOVE TRANSFER CASE NO.1 PLUG

- (a) Remove the transfer case plug No.1 (filler plug) and gasket.

27. REMOVE TRANSFER CASE NO.1 PLUG

- (a) Remove the transfer case plug No.1 (drain plug) and gasket.

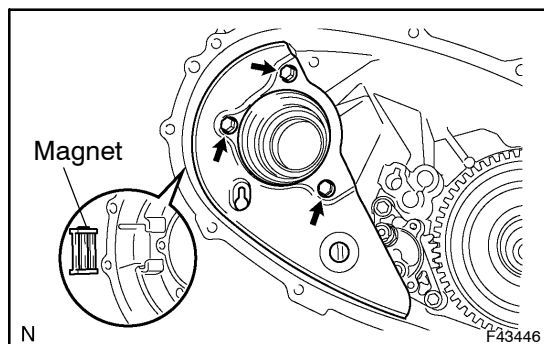

28. REMOVE TRANSFER OIL SEPARATOR SUB-ASSY

- (a) Remove the 3 bolts and oil separator sub-assy.

29. REMOVE TRANSFER CASE MAGNET

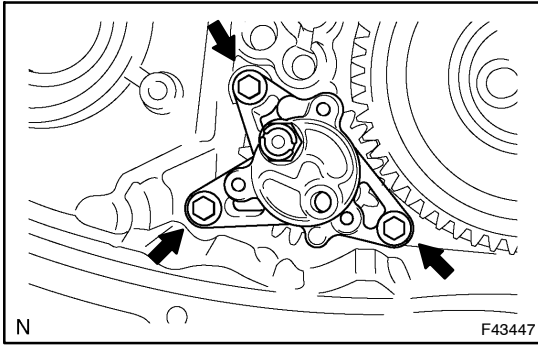
**30. REMOVE TRANSFER OIL PUMP BODY SUB-ASSY**

- (a) Remove the 3 bolts and oil pump body sub-assy.

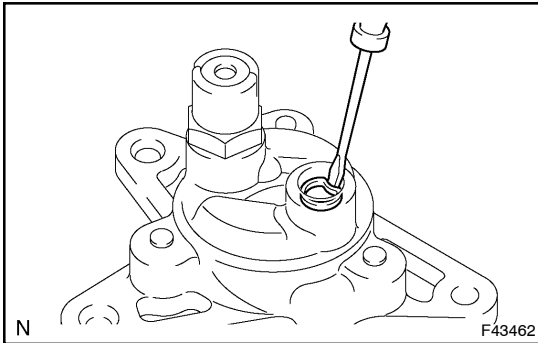
**31. REMOVE TRANSFER OIL PUMP BODY O-RING**

- (a) Using a screwdriver, remove the oil pump body O-ring.

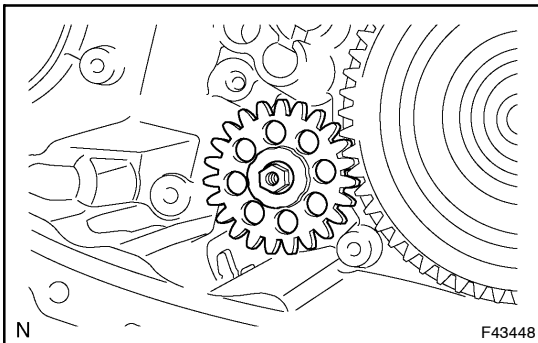
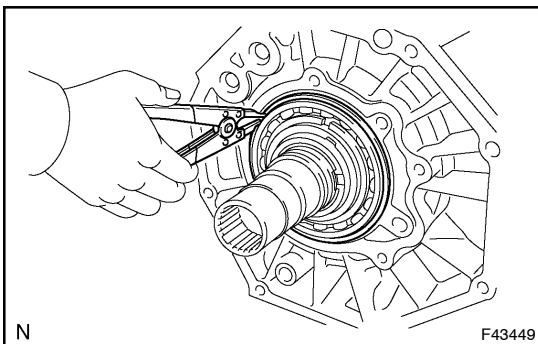
**32. REMOVE TRANSFER OIL PUMP GEAR****33. REMOVE LOW PLANETARY GEAR ASSY W/INPUT SHAFT SUB-ASSY**

- (a) Using a snap ring expander, remove the snap ring.

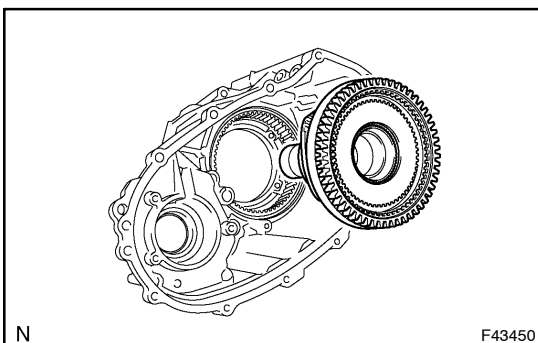

- (b) Remove the low planetary gear assy and input shaft sub-assy.

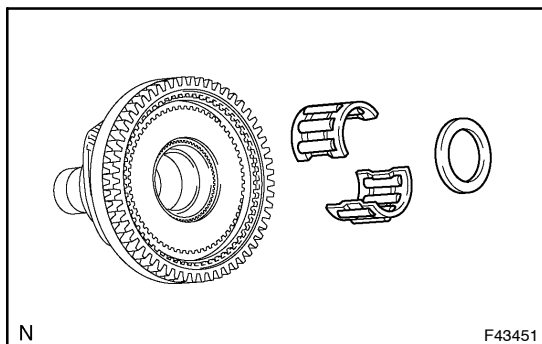

34. REMOVE TRANSFER OUTPUT SHAFT SPACER
 35. REMOVE TRANSFER OUTPUT SHAFT FRONT NEEDLE ROLLER BEARING

36. REMOVE TRANSFER CASE OIL SEAL

- (a) Using a screwdriver and hammer, remove the transfer case oil seal (No.1).
 (b) Using a screwdriver and hammer, remove the transfer case oil seal (No.2).

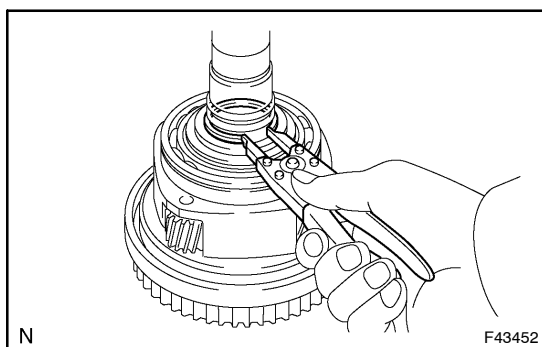

37. REMOVE TRANSFER INPUT GEAR STOPPER SHAFT SNAP RING

- (a) Using a snap ring expander, remove the input gear stopper shaft snap ring.

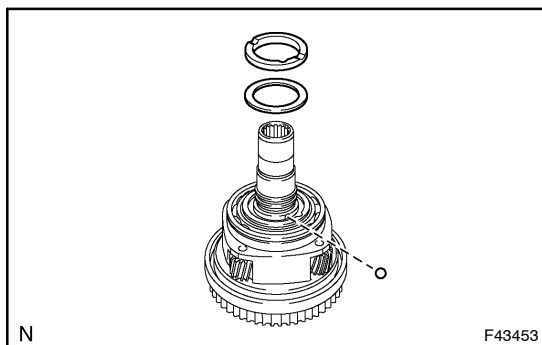

38. REMOVE TRANSFER INPUT GEAR STOPPER
 39. REMOVE TRANSFER INPUT GEAR STOPPER BALL
 40. REMOVE MANUAL TRANSFER PLANETARY CARR WASHER

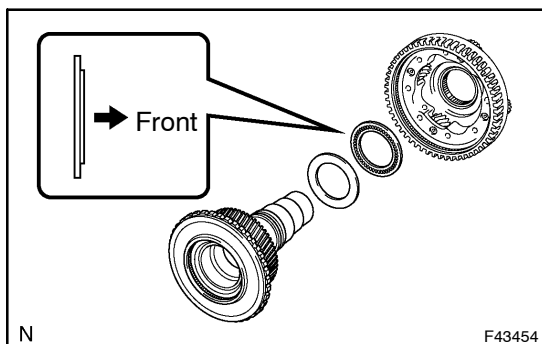

41. REMOVE TRANSFER INPUT SHAFT
 42. REMOVE TRANSFER THRUST BEARING RACE NO.1
 43. REMOVE TRANSFER LOW PLANETARY GEAR BEARING

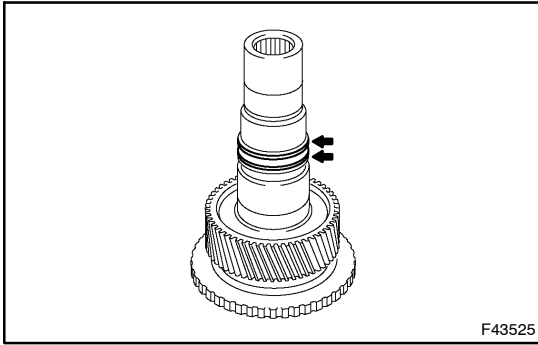

44. REMOVE TRANSFER INPUT SHAFT SEAL RING NO.1

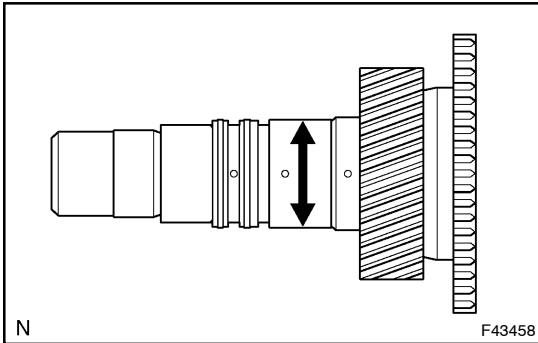

45. INSPECT TRANSFER INPUT SHAFT

- (a) Using a micrometer, measure the outer diameter of the input shaft journal surface.

Minimum diameter: 47.59 mm (1.8736 in.)

If the outer diameter is less than the minimum, replace the input shaft.

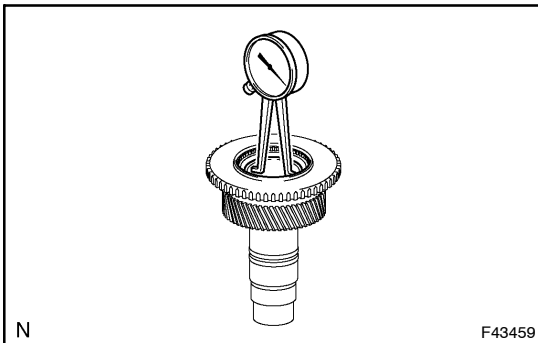

- (b) Using a dial indicator, measure the inside diameter of the input shaft bushing.

Maximum diameter: 48.14 mm (1.8953 in.)

If the inside diameter exceeds the maximum, replace the input shaft.

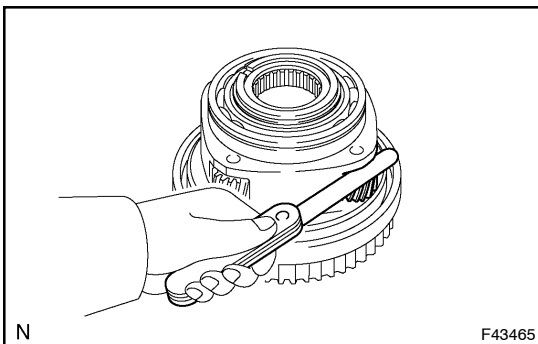

46. INSPECT PLANETARY PINION GEAR THRUST CLEARANCE

- (a) Using a feeler gauge, measure the thrust clearance of the planetary pinion gear.

Standard clearance:

0.11 - 0.84 mm (0.0043 - 0.0331 in.)

Maximum clearance:

0.84 mm (0.0331 in.)

If the clearance exceeds the maximum, replace the planetary gear assy.

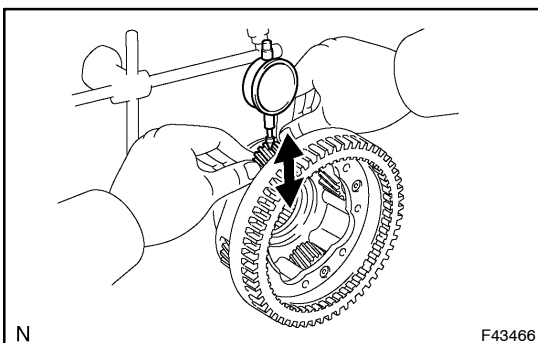

47. INSPECT PLANETARY PINION GEAR RADIAL CLEARANCE

- (a) Using a dial indicator, measure the radial clearance of the planetary pinion gear.

Standard clearance:

0.009 - 0.038 mm (0.0004 - 0.0015 in.)

Maximum clearance:

0.038 mm (0.0015 in.)

If the clearance exceeds the maximum, replace the planetary gear assy.

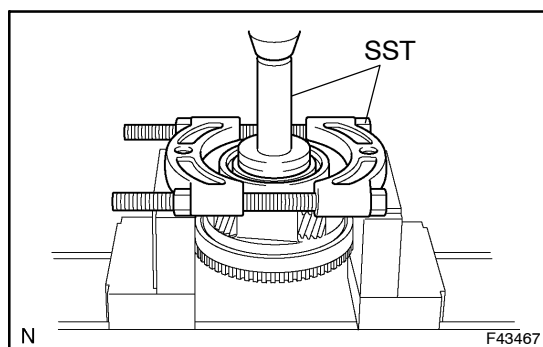
**48. REMOVE TRANSFER INPUT SHAFT BEARING**

- (a) Using a snap ring expander, remove the snap ring.
- (b) Using SST and a press, remove the input shaft bearing.
SST 09554-30011, 09555-55010

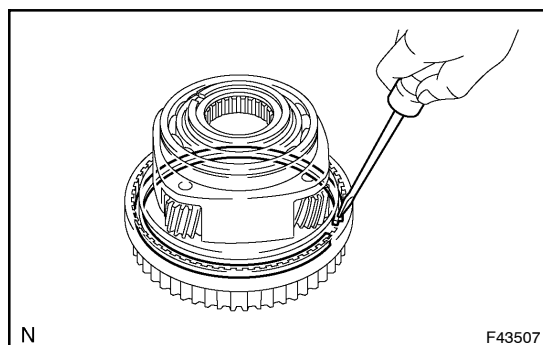
**49. REMOVE TRANSFER LOW PLANETARY GEAR SPLINE PIECE**

- (a) Using a screwdriver, remove the snap ring.
- (b) Remove the low planetary gear spline piece.

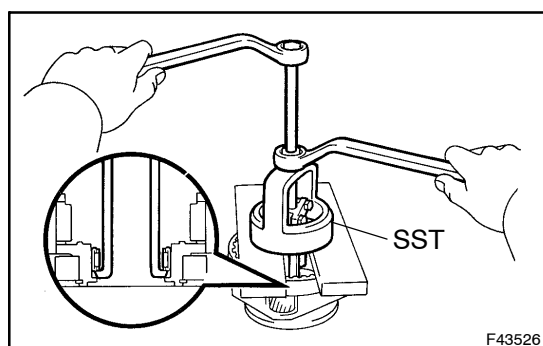
**50. REMOVE TRANSFER LOW PLANETARY GEAR BEARING**

- (a) Using SST, remove the low planetary gear bearing.
SST 09612-65014 (09612-01030, 09612-01050)

NOTICE:

Hang SST securely to the clearance between the bearing and low planetary gear.

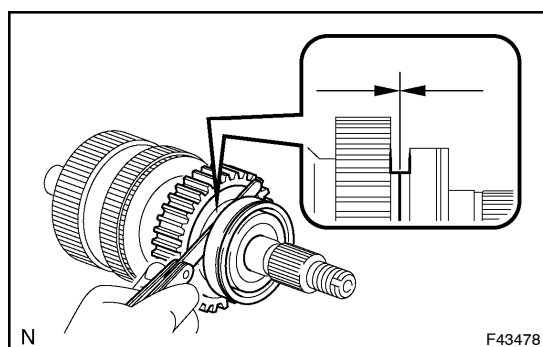
**51. INSPECT DRIVE SPROCKET THRUST CLEARANCE**

- (a) Using a feeler gauge, measure the thrust clearance of the drive sprocket.

Standard clearance:

0.15 - 0.24 mm (0.0059 - 0.0094 in.)

Maximum clearance:

0.24 mm (0.0094 in.)

If the clearance exceeds the maximum, replace the drive sprocket.

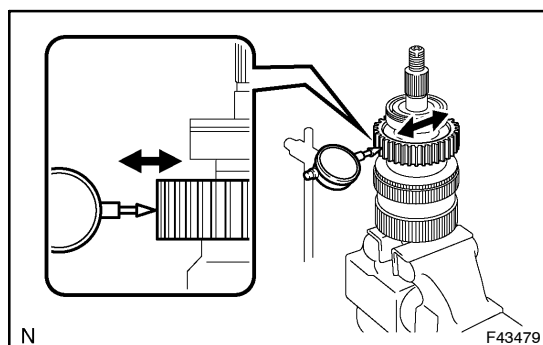
**52. INSPECT DRIVE SPROCKET RADIAL CLEARANCE**

- (a) Using a dial indicator, measure the radial clearance of the drive sprocket.

Standard clearance:

0.01 - 0.06 mm (0.0004 - 0.0024 in.)

Maximum clearance:

0.06 mm (0.0024 in.)

If the clearance exceeds the maximum, replace the drive sprocket, output shaft rear or needle roller bearing.

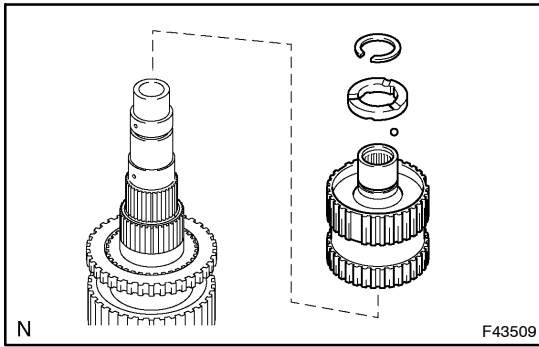

53. REMOVE TRANSFER LOW PLANETARY RING GEAR HOLE SNAP RING

(a) Using a snap ring expander, remove the snap ring.

54. REMOVE TRANSFER OUTPUT SHAFT SPACER NO.2

55. REMOVE TRANSFER OUTPUT SHAFT SPACER BALL

56. REMOVE CENTER DIFFERENTIAL CASE

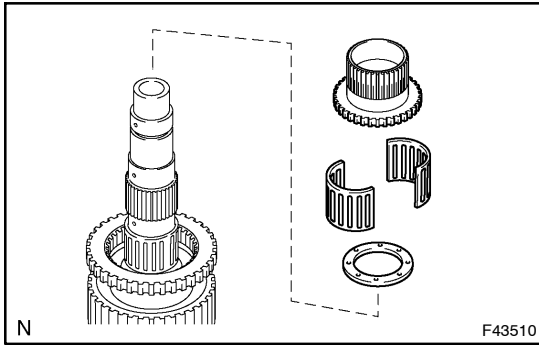

57. REMOVE TRANSFER CLUTCH HUB

58. REMOVE TRANSFER OUTPUT SHAFT FRONT NEEDLE ROLLER BEARING

59. REMOVE TRANSFER OUTPUT SHAFT PLATE WASHER

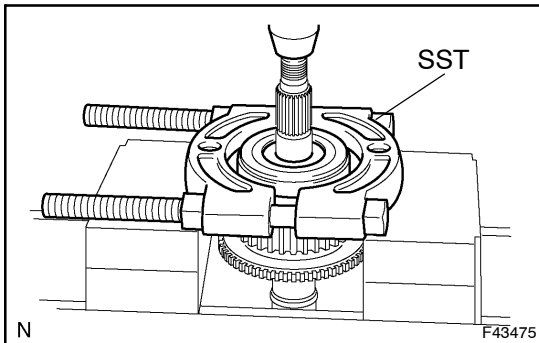

60. REMOVE TRANSFER OUTPUT SHAFT REAR RADIAL BALL BEARING

(a) Using SST and a press, remove the output shaft rear radial ball bearing.

SST 09555-55010

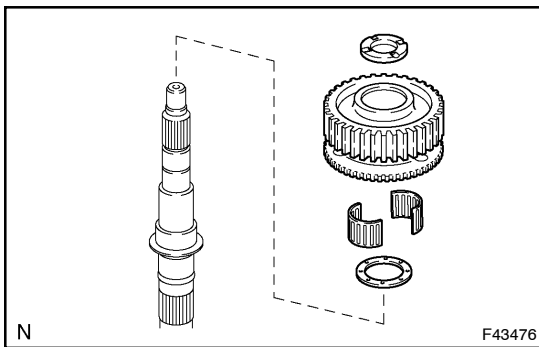

61. REMOVE TRANSFER OUTPUT SHAFT SPACER NO.1

62. REMOVE TRANSFER DRIVE SPROCKET SUB-ASSY

63. REMOVE TRANSFER DRIVE SPROCKET BEARING

64. REMOVE TRANSFER OUTPUT SHAFT PLATE WASHER

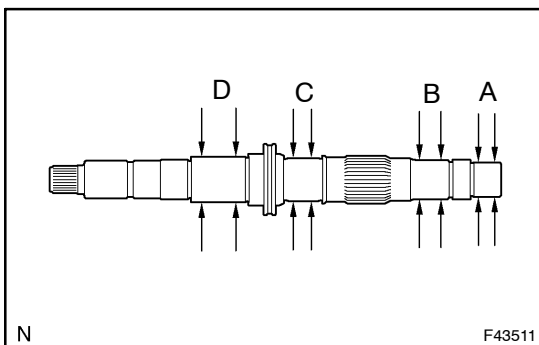

65. INSPECT TRANSFER OUTPUT SHAFT REAR

(a) Using a micrometer, measure the outer diameter of the output shaft rear journal surface.

Standard diameter:

Part A: 27.98 - 27.99 mm (1.1016 - 1.1020 in.)

Part B: 31.98 - 32.00 mm (1.2591 - 1.2598 in.)

Part C: 34.98 - 35.00 mm (1.3772 - 1.3780 in.)

Part D: 36.98 - 37.00 mm (1.4559 - 1.4567 in.)

Minimum Diameter:**Part A: 27.98 mm (1.1016 in.)****Part B: 31.98 mm (1.2591 in.)****Part C: 34.98 mm (1.3772 in.)****Part D: 36.98 mm (1.4559 in.)**

If the outer diameter is less than the minimum, replace the output shaft rear.

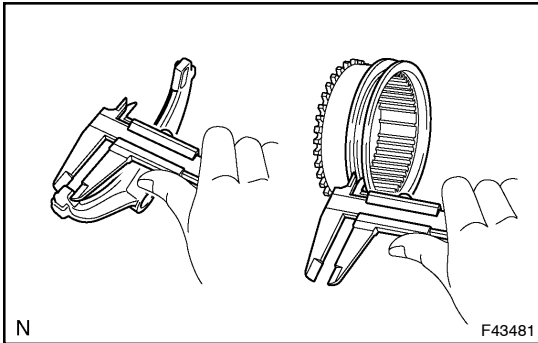
**66. INSPECT HIGH AND LOW CLUTCH SLEEVE AND GEAR SHIFT FORK NO.2 CLEARANCE**

- (a) Using vernier calipers, measure the thickness of the gear shift fork No.2 claw.

Thickness: 10 mm (0.3937 in.)

- (b) Using vernier calipers, measure the groove of the high and low clutch sleeve.

Distance: 10.5 mm (0.4134 in.)

- (c) Calculate a clearance between the high and low clutch sleeve and gear shift fork No.2 clearance.

Standard clearance:**0.26 - 0.84 mm (0.0102 - 0.0331 in.)****Maximum clearance:****0.84 mm (0.0331 in.)**

If the clearance exceeds the maximum, replace the high and low clutch sleeve or gear shift fork No.2.

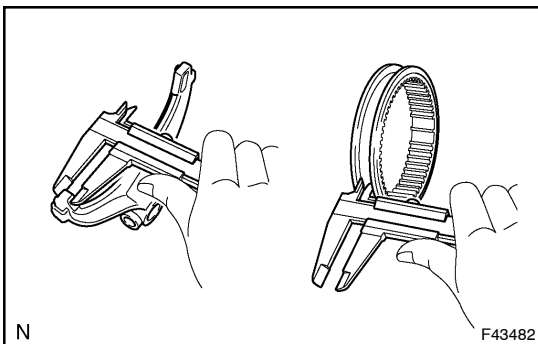
**67. INSPECT FRONT DRIVE CLUTCH SLEEVE AND CTR DIFFERENTIAL LOCK FORK SUB-ASSY CLEARANCE**

- (a) Using vernier calipers, measure the thickness of the CTR differential lock fork claw.

Thickness: 10 mm (0.397 in.)

- (b) Using vernier calipers, measure the groove of the front drive clutch sleeve.

Distance: 10.5 mm (0.4134 in.)

- (c) Calculate a clearance between the front drive clutch sleeve and CTR differential lock fork.

Standard clearance:**0.26 - 0.84 mm (0.0102 - 0.0331 in.)****Maximum clearance:****0.84 mm (0.0331 in.)**

If the clearance exceeds the maximum, replace the front drive clutch sleeve or CTR differential lock fork.

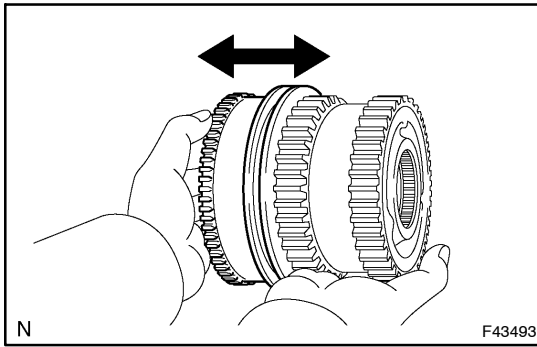

68. INSPECT CENTER DIFFERENTIAL CASE AND HIGH AND LOW CLUTCH SLEEVE

- (a) Check that the tip of the spline gear of the high and low clutch sleeve is not worn.
- (b) Install the high and low clutch sleeve to the center differential case and check that the high and low clutch sleeve moves smoothly.

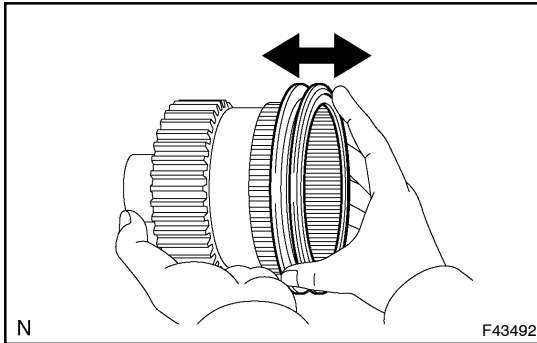

69. INSPECT CENTER DIFFERENTIAL CASE AND FRONT DRIVE CLUTCH SLEEVE

- (a) Check that the tip of the spline gear of the front drive clutch sleeve is not worn.
- (b) Install the front drive clutch sleeve to the center differential case and check that the front drive clutch sleeve moves smoothly.

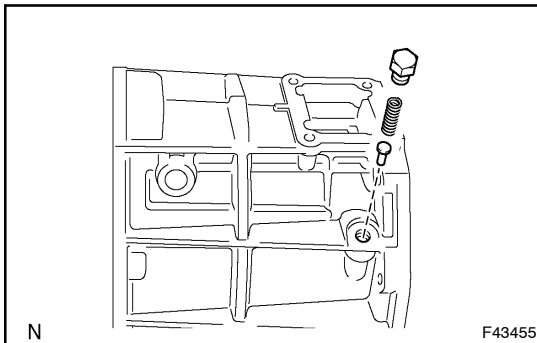

- 70. REMOVE TRANSFER CASE PLUG**
- 71. REMOVE COMPRESSION SPRING**
- 72. REMOVE PIN**

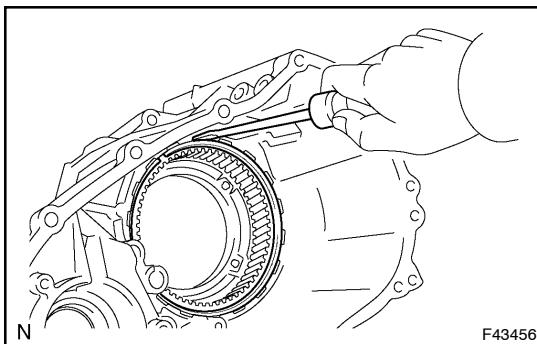

73. REMOVE TRANSFER LOW PLANETARY RING GEAR

- (a) Using a screwdriver, remove the snap ring.
- (b) Remove the low planetary ring gear from the front case.

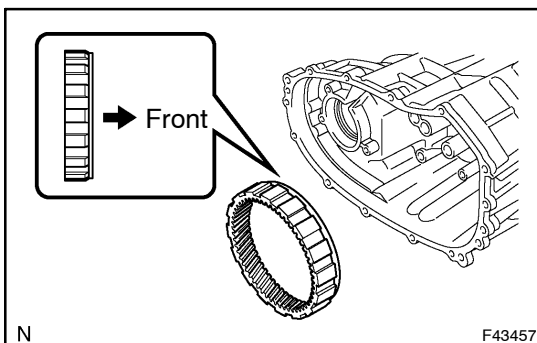

74. INSTALL TRANSFER LOW PLANETARY RING GEAR

- (a) Install the low planetary ring gear to the front case.

NOTICE:

Make sure to install the low planetary ring gear in the correct direction.

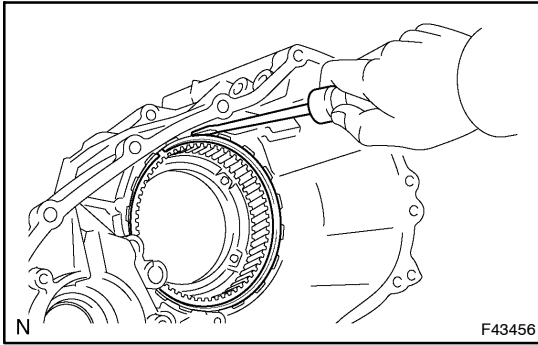

- (b) Using a screwdriver, install the snap ring.

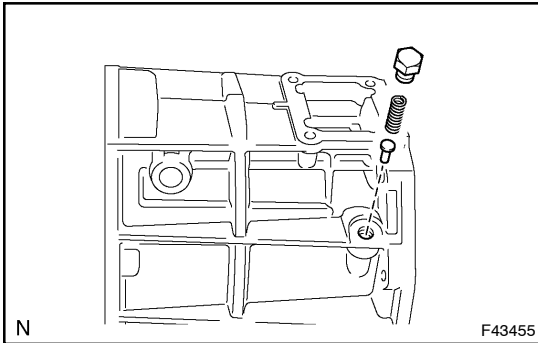

75. INSTALL PIN

76. INSTALL COMPRESSION SPRING

77. INSTALL TRANSFER CASE PLUG

- (a) Apply sealant to the case plug threads.

Sealant:

Part No. 08833-00080, THREE BOND 1344, LOCTITE 242 or equivalent

- (b) Install the case plug.

Torque: 19 N·m (190 kgf·cm, 14 ft·lbf)

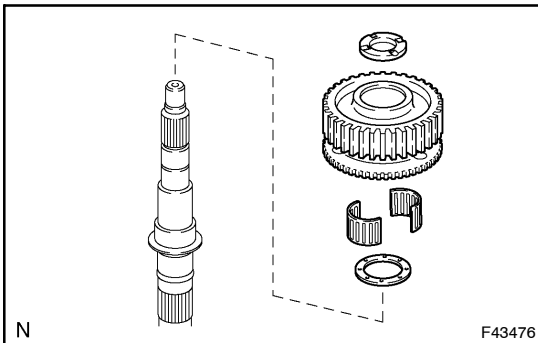

78. INSTALL TRANSFER OUTPUT SHAFT PLATE WASHER

79. INSTALL TRANSFER DRIVE SPROCKET BEARING

80. INSTALL TRANSFER DRIVE SPROCKET SUB-ASSY

81. INSTALL TRANSFER OUTPUT SHAFT SPACER NO.1

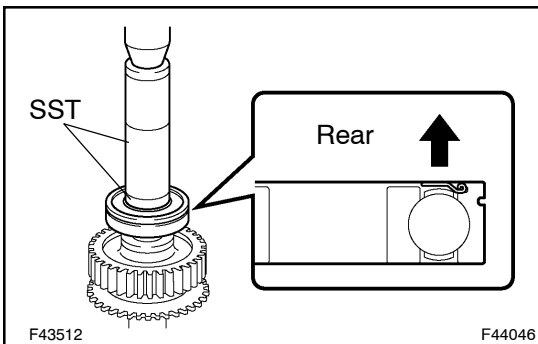

82. INSTALL TRANSFER OUTPUT SHAFT REAR RADIAL BALL BEARING

- (a) Using SST and a press, install a new output shaft rear radial ball bearing.

SST 09316-60011 (09316-00011, 09316-00071)

NOTICE:

Install the output shaft rear radial ball bearing so that the bearing snap ring groove faces to the rear.

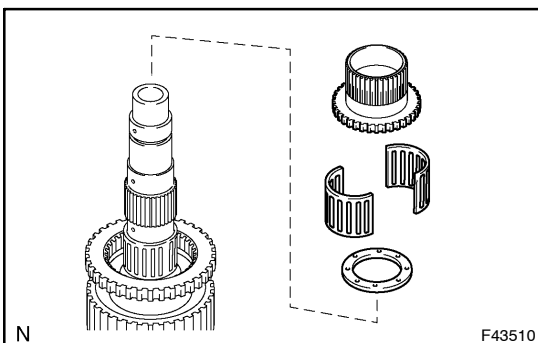

83. INSTALL TRANSFER OUTPUT SHAFT PLATE WASHER

84. INSTALL TRANSFER OUTPUT SHAFT FRONT NEEDLE ROLLER BEARING

85. INSTALL TRANSFER CLUTCH HUB

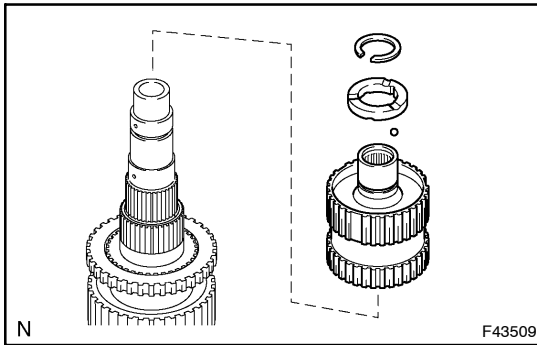

86. **INSTALL CENTER DIFFERENTIAL CASE**
 87. **INSTALL TRANSFER OUTPUT SHAFT SPACER BALL**
 88. **INSTALL TRANSFER OUTPUT SHAFT SPACER NO.2**
 89. **INSTALL TRANSFER LOW PLANETARY RING GEAR HOLE SNAP RING**

(a) Using a snap ring expander, install the snap ring.

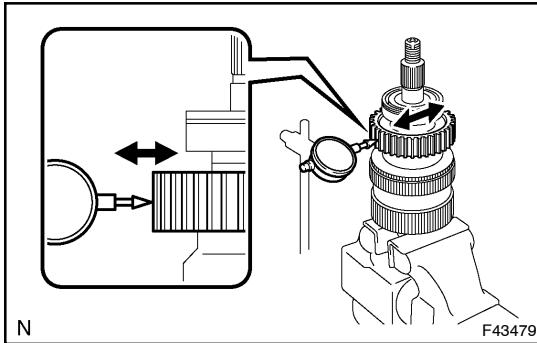

90. **INSPECT DRIVE SPROCKET RADIAL CLEARANCE**

(a) Using a dial indicator, measure the radial clearance of the drive sprocket.

Standard clearance:

0.01 - 0.06 mm (0.0004 - 0.0024 in.)

Maximum clearance:

0.06 mm (0.0024 in.)

If the clearance exceeds the maximum, replace the drive sprocket, output shaft rear or needle roller bearing.

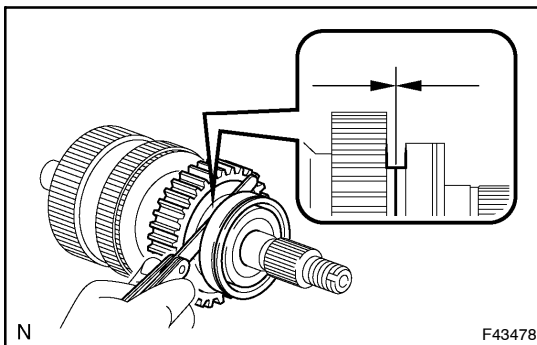

91. **INSPECT DRIVE SPROCKET THRUST CLEARANCE**

(a) Using a feeler gauge, measure the thrust clearance of the drive sprocket.

Standard clearance:

0.15 - 0.24 mm (0.0059 - 0.0094 in.)

Maximum clearance:

0.24 mm (0.0094 in.)

If the clearance exceeds the maximum, replace the drive sprocket.

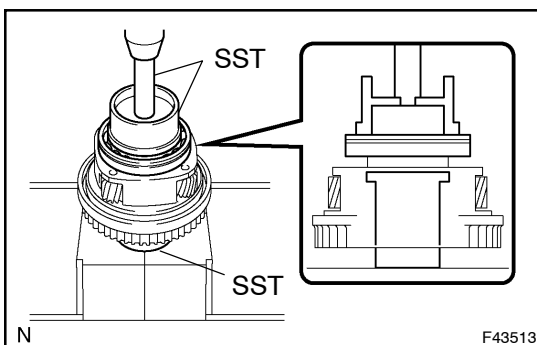

92. **INSTALL TRANSFER INPUT SHAFT BEARING**

(a) Using SST and a press, install a new bearing with the groove facing forward.

SST 09223-15020, 09515-30010, 09950-70010
 (09951-07100)

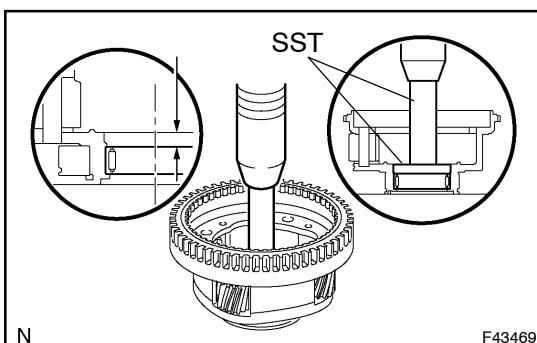

93. **INSTALL TRANSFER LOW PLANETARY GEAR BEARING**

(a) Using SST and a press, drive in a new bearing.

SST 09950-60010 (09951-00570), 09950-70010
 (09951-07100)

Bearing press in depth:

7.7 - 8.3 mm (0.303 - 0.327 in.)

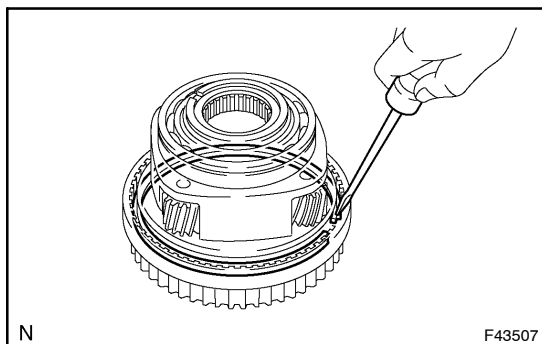

94. INSTALL TRANSFER LOW PLANETARY GEAR SPLINE PIECE

- (a) Using a screwdriver, install the spline piece with the snap ring.

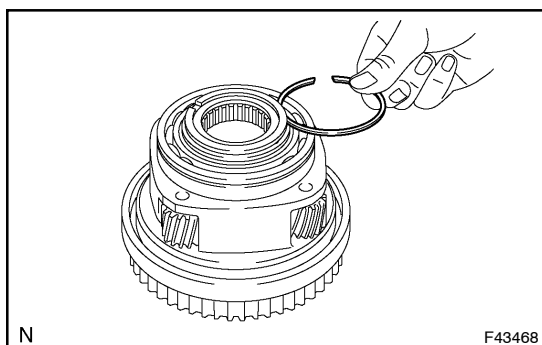

95. INSTALL TRANSFER INPUT BEARING SHAFT SNAP RING

- (a) Select a snap ring that allows 0.1 mm (0.0039 in.) or less axial play.

Mark	Thickness mm (in.)
1	1.45 - 1.50 (0.0571 - 0.0591)
2	1.50 - 1.55 (0.0591 - 0.0610)
3	1.55 - 1.60 (0.0610 - 0.0630)
4	1.60 - 1.65 (0.0630 - 0.0650)
5	1.65 - 1.70 (0.0650 - 0.0669)

- (b) Using a snap ring expander, install a new snap ring.

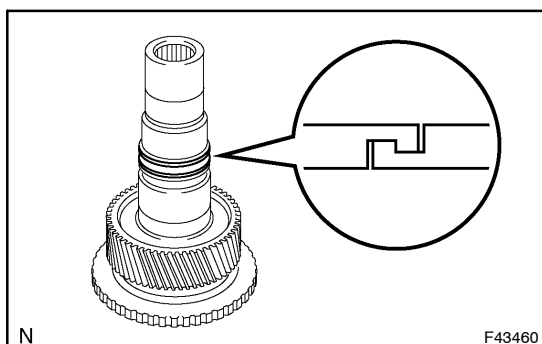

96. INSTALL TRANSFER INPUT SHAFT SEAL RING NO.1

HINT:

- Apply gear oil to the 2 oil seal rings.
- Engage securely to eliminate clearance as shown in the illustration.

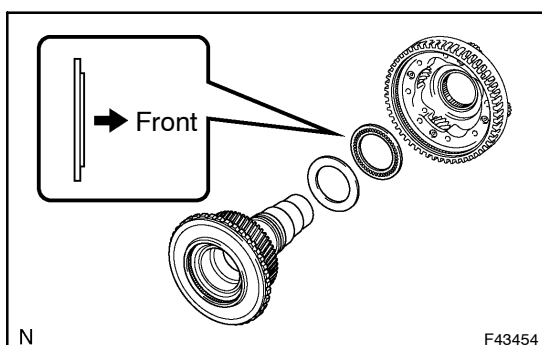

97. INSTALL TRANSFER LOW PLANETARY GEAR BEARING

NOTICE:

Make sure to install the transfer low planetary gear bearing in the correct direction.

98. INSTALL TRANSFER THRUST BEARING RACE NO.1

99. INSTALL TRANSFER INPUT SHAFT

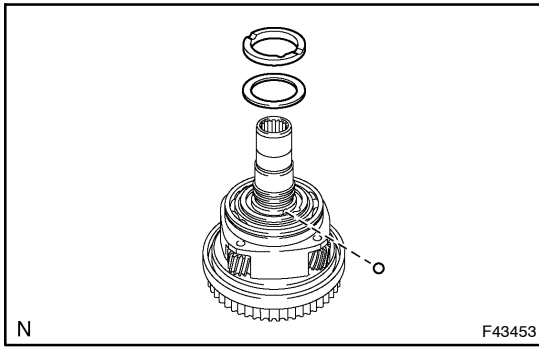

- 100. INSTALL MANUAL TRANSFER PLANETARY CARR WASHER
- 101. INSTALL TRANSFER INPUT GEAR STOPPER BALL
- 102. INSTALL TRANSFER INPUT GEAR STOPPER

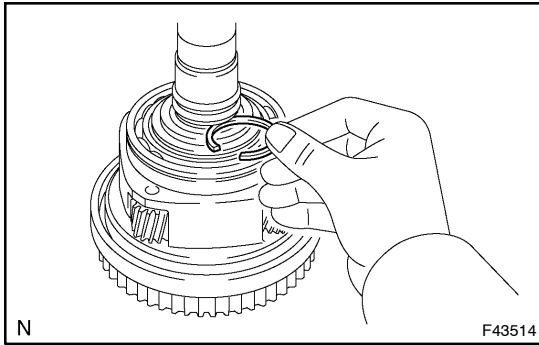

- 103. INSTALL TRANSFER INPUT GEAR STOPPER SHAFT SNAP RING
- (a) Select a input gear stopper snap ring that allows 0.05 - 0.15 mm (0.0020 - 0.0059 in.) axial play.

Mark	Thickness mm (in.)
A	2.10 - 2.15 (0.0827 - 0.0846)
B	2.15 - 2.20 (0.0846 - 0.0866)
C	2.20 - 2.25 (0.0866 - 0.0886)
D	2.25 - 2.30 (0.0886 - 0.0906)
E	2.30 - 2.35 (0.0906 - 0.0925)
F	2.35 - 2.40 (0.0925 - 0.0945)
G	2.40 - 2.45 (0.0945 - 0.0965)
H	2.45 - 2.50 (0.0965 - 0.0984)
J	2.50 - 2.55 (0.0984 - 0.1004)
K	2.55 - 2.60 (0.1004 - 0.1204)
L	2.60 - 2.65 (0.1024 - 0.1043)
M	2.65 - 2.70 (0.1043 - 0.1063)
N	2.70 - 2.75 (0.1063 - 0.1083)
P	2.75 - 2.80 (0.1083 - 0.1102)
Q	2.80 - 2.85 (0.1102 - 0.1122)
R	2.85 - 2.90 (0.1122 - 0.1142)
S	2.90 - 2.95 (0.1142 - 0.1161)
T	2.95 - 3.00 (0.1161 - 0.1181)
U	3.00 - 3.05 (0.1181 - 0.1201)

- (b) Using a snap ring expander, install a new input gear stopper snap ring.

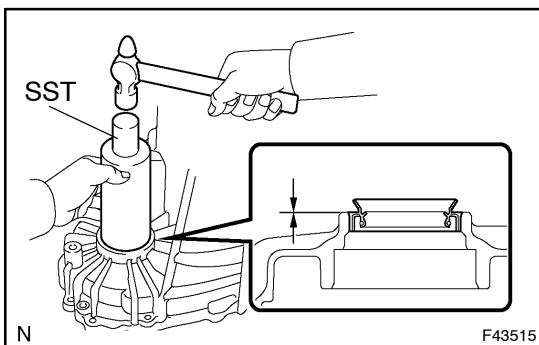

- 104. INSTALL TRANSFER CASE OIL SEAL
- (a) Using SST and a hammer, drive in a new oil seal until its surface is flush with the case upper surface. (No.1) SST 09316-60011 (09316-00011)
- (b) Coat the lip of the oil seal with MP grease.

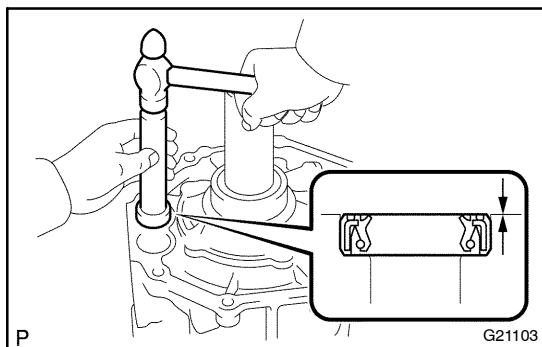

- (c) Using SST and a hammer, drive in a new oil seal until its surface is flush with the case upper surface. (No.2)
SST 09304-12012
Oil seal drive in depth:
-0.5 - 0.5 mm (-0.020 - 0.020 in.)
- (d) Coat the lip of the oil seal with MP grease.

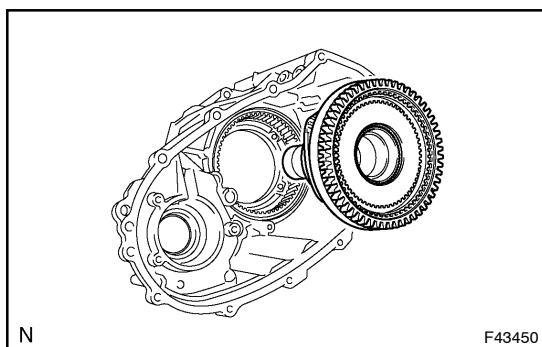

105. INSTALL LOW PLANETARY GEAR ASSY W/INPUT SHAFT SUB-ASSY

- (a) Install the low planetary gear assy with input shaft sub-assy.

HINT:

If necessary, heat the front case to about 50 - 80°C (122 - 176°F).

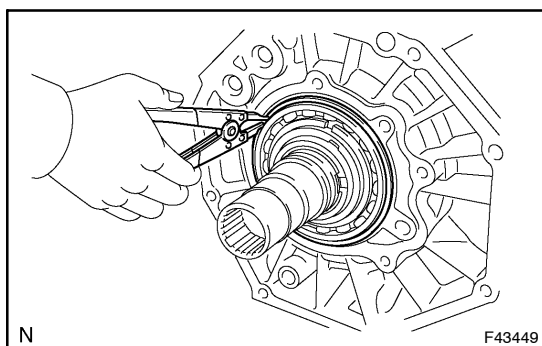

- (b) Using a snap ring expander, install the snap ring.

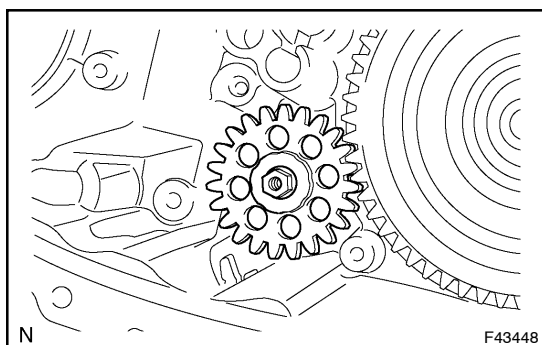

106. INSTALL TRANSFER OIL PUMP GEAR

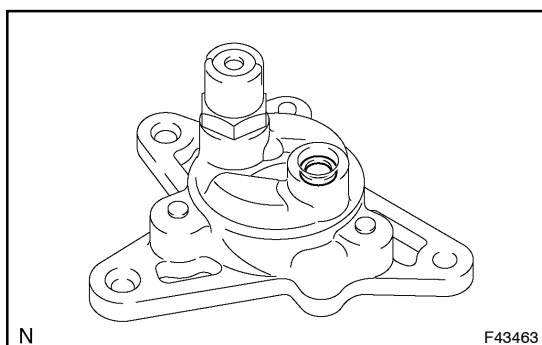

107. INSTALL TRANSFER OIL PUMP BODY O-RING

- (a) Coat a new O-ring with gear oil and install it to the oil pump body.

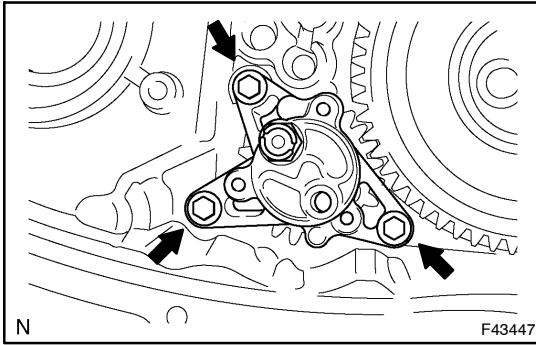
**108. INSTALL TRANSFER OIL PUMP BODY SUB-ASSY**

- (a) Install the oil pump body sub-assy with the 3 bolts.
Torque: 7.5 N·m (76 kgf·cm, 66 in·lbf)

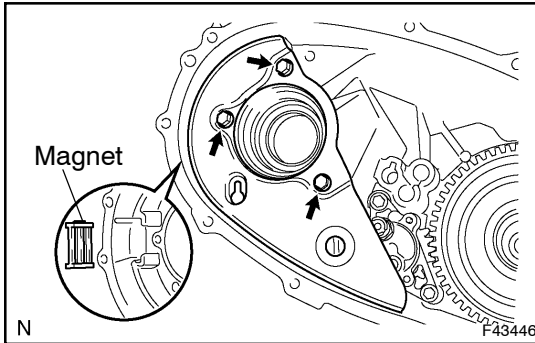
**109. INSTALL TRANSFER CASE MAGNET****110. INSTALL TRANSFER OIL SEPARATOR SUB-ASSY**

- (a) Install the oil separator sub-assy with the 3 bolts.
Torque: 7.5 N·m (76 kgf·cm, 66 in·lbf)

111. INSTALL TRANSFER CASE NO.1 PLUG

- (a) Install the case No.1 plug (filler plug) and a new gasket.
Torque: 37 N·m (377 kgf·cm, 27 ft·lbf)

112. INSTALL TRANSFER CASE NO.1 PLUG

- (a) Install the case No.1 plug (drain plug) and a new gasket.
Torque: 37 N·m (377 kgf·cm, 27 ft·lbf)

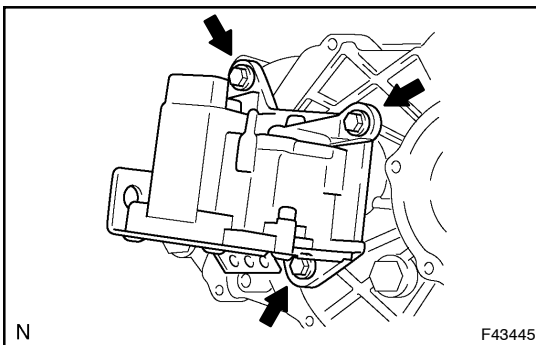
**113. INSTALL TRANSFER SHIFT ACTUATOR ASSY**

- (a) Install the actuator assy with the 3 bolts.
Torque: 20 N·m (204 kgf·cm, 15 ft·lbf)
 (b) Using a screwdriver and hammer, drive in the 2 snap rings.

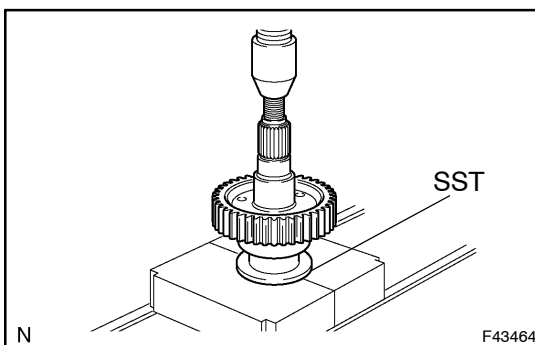
**114. INSTALL TRANSFER INPUT GEAR RADIAL BALL BEARING**

- (a) Using SST and a press, install a new input gear radial ball bearing.
 SST 09316-60011 (09316-00031)

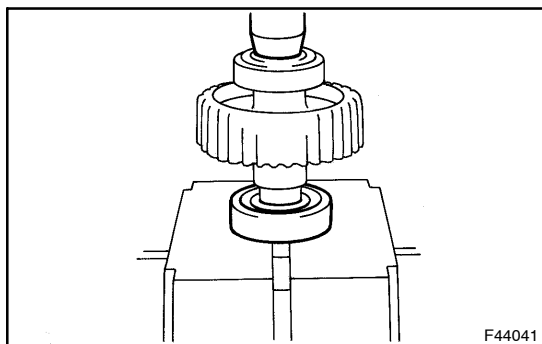
**115. INSTALL TRANSFER DRIVEN SPROCKET BEARING**

- (a) Using a press, install a new driven sprocket bearing.

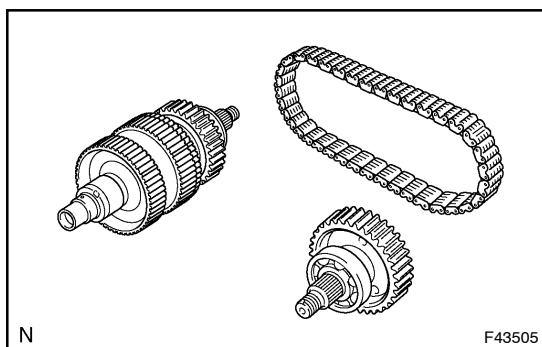
**116. INSTALL REAR OUTPUT SHAFT SUB-ASSY, FRONT DRIVE CHAIN AND DRIVEN SPROCKET SUB-ASSY**

- (a) Install the rear output shaft sub-assy and drive sprocket to the front drive chain.

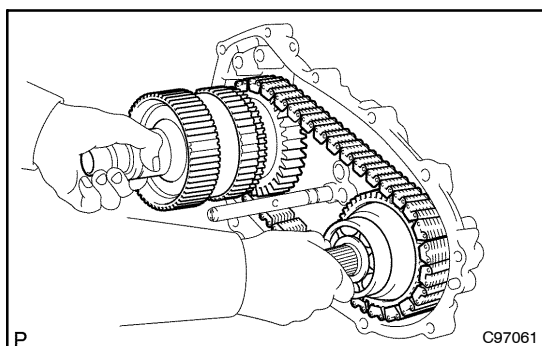

- (b) Install the rear output shaft sub-assy, front drive chain and driven sprocket sub-assy to the case rear.

HINT:

Check that the rear output shaft sub-assy and driven sprocket sub-assy turn lightly.

If necessary, that the rear case about 50 - 80°C (122 - 176°F).

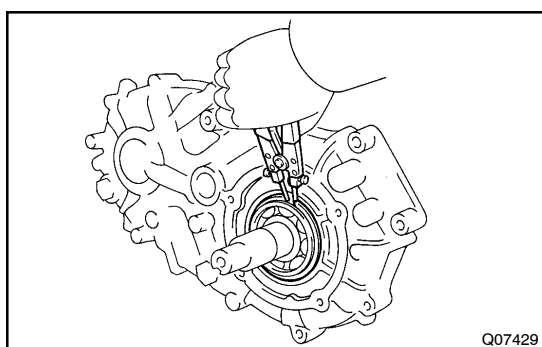

- (c) Using a snap ring expander, install the snap ring.

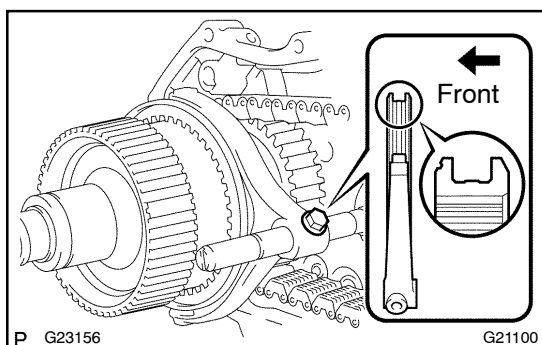
**117. INSTALL CTR DIFFERENTIAL LOCK FORK SUB-ASSY W/FRONT DRIVE CLUTCH SLEEVE**

- (a) Install the CTR differential lock fork sub-assy and front drive clutch sleeve.

- (b) Install the bolt.

Torque: 24 N·m (245 kgf·cm, 18 ft·lbf)

- (c) Using a screwdriver and hammer, drive in the snap ring.

NOTICE:

Make sure to install the fork and clutch sleeve in the correct direction.

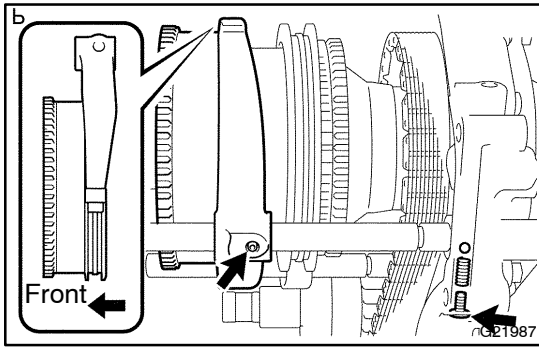

118. INSTALL TRANSFER GEAR SHIFT FORK NO.2 W/TRANSFER HIGH AND LOW CLUTCH SLEEVE

- (a) Install the gear shift fork No.2 and high and low shift fork shaft and high and low clutch sleeve.

NOTICE:

Make sure to install the fork in the correct direction.

- (b) Apply sealant to the plug No.1 threads.

Sealant:

Part No. 08833-00080, THREE BOND 1344, LOCTITE 242 or equivalent

- (c) Install the spring and ball to the hole.

- (d) Install the plug No.1 to the hole.

Torque: 19 N·m (190 kgf·cm, 14 ft·lbf)

- (e) Using a pin punch and hammer, Install the slotted pin.

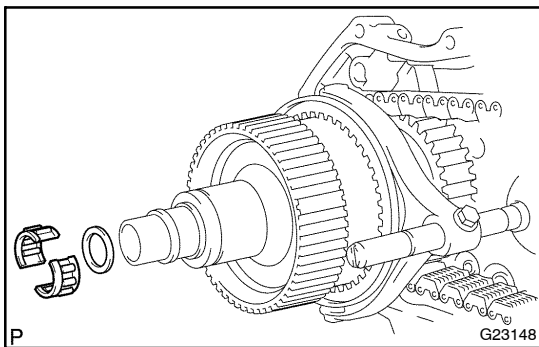

119. INSTALL TRANSFER OUTPUT SHAFT SPACER

120. INSTALL TRANSFER OUTPUT SHAFT FRONT NEEDLE ROLLER BEARING

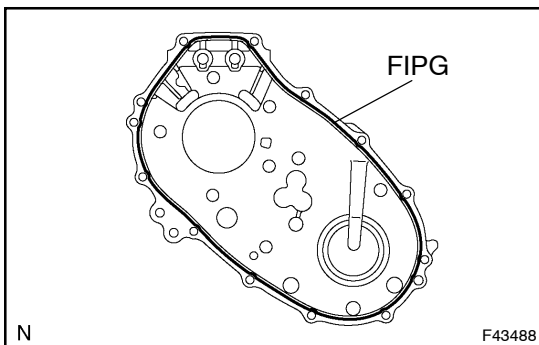

121. INSTALL TRANSFER CASE REAR

- (a) Apply FIPG to the case rear, as shown.

FIPG:

Part No. 08826-00090, THREE BOND 1281 or equivalent

- (b) Install the 2 clamps and case rear with the 12 bolts.

Torque: 28 N·m (285 kgf·cm, 21 ft·lbf)

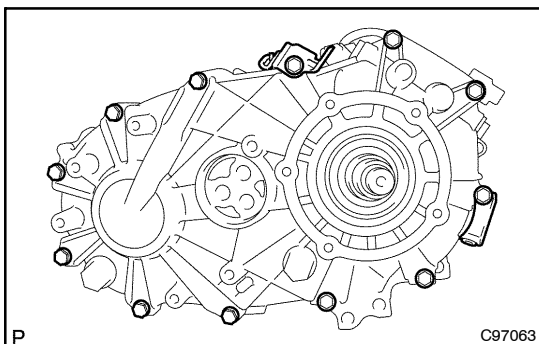

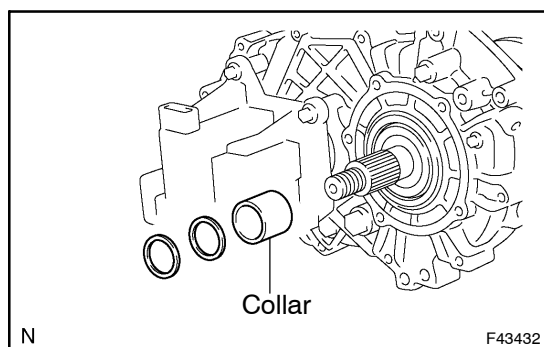
**122. INSTALL TRANSFER OUTPUT WASHER**

- (a) Install the collar and 2 output washers.

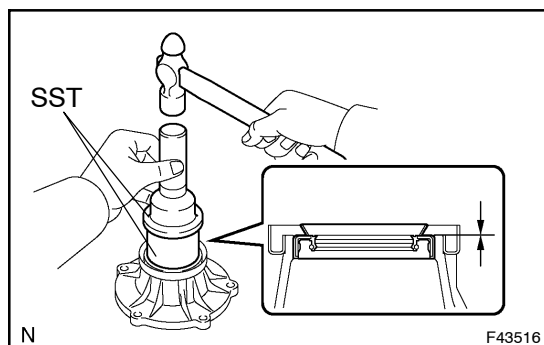
**123. INSTALL TRANSFER EXTENSION HOUSING TYPE T OIL SEAL**

- (a) Using SST and a hammer, drive in a new oil seal until its surface is flush with the housing upper surface.
SST 09223-46011, 09631-32020
- (b) Coat the lip of the oil seal with MP grease.

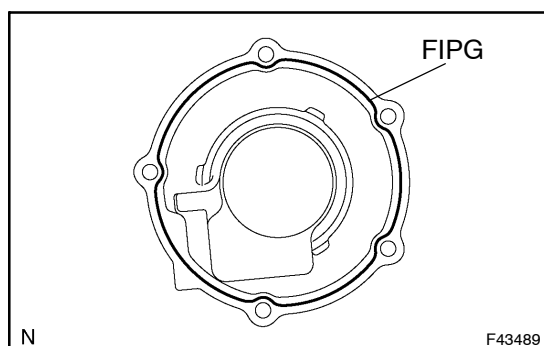
**124. INSTALL EXTENSION HOUSING ASSY**

- (a) Apply FIPG to the extension housing assy rear, as shown.
FIPG:
Part No. 08826-00090, THREE BOND 1281 or equivalent
- (b) Apply sealant to the bolt threads.
Sealant:
Part No. 08833-00080, THREE BOND 1344, LOCTITE 242 or equivalent

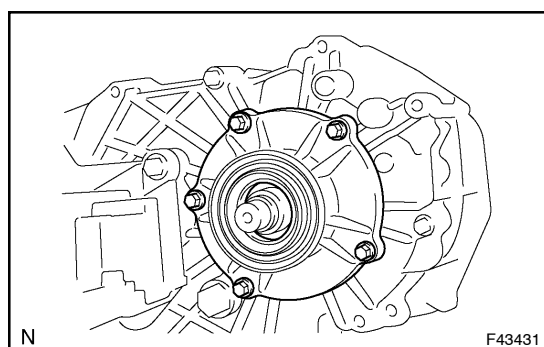

- (c) Install the extension housing assy with the 5 bolts.
Torque: 12 N·m (122 kgf·cm, 9 ft·lbf)

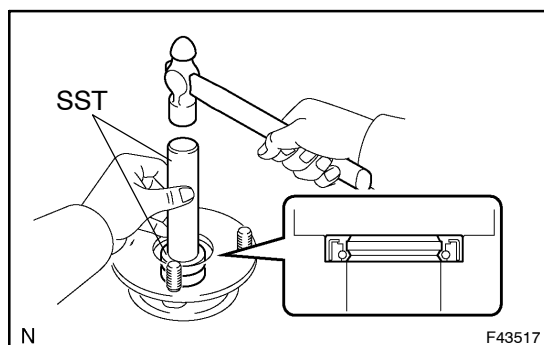
**125. INSTALL TRANSFER OUTPUT SHAFT COMPANION FLANGE OIL SEAL**

- (a) Using SST and a hammer, drive in a new oil seal (front).
SST 09950-60010 (09951-00320), 09950-70010 (09951-07100)
- (b) Coat the lip of the oil seal with MP grease.

126. INSTALL TRANSFER OUTPUT SHAFT COMPANION FLANGE OIL SEAL

- (a) Drive in a new oil seal (rear) in the same way as the oil seal (front).

SST 09950-60010 (09951-00320), 09950-70010 (09951-07100)

- (b) Coat the lip of the oil seal with MP grease.

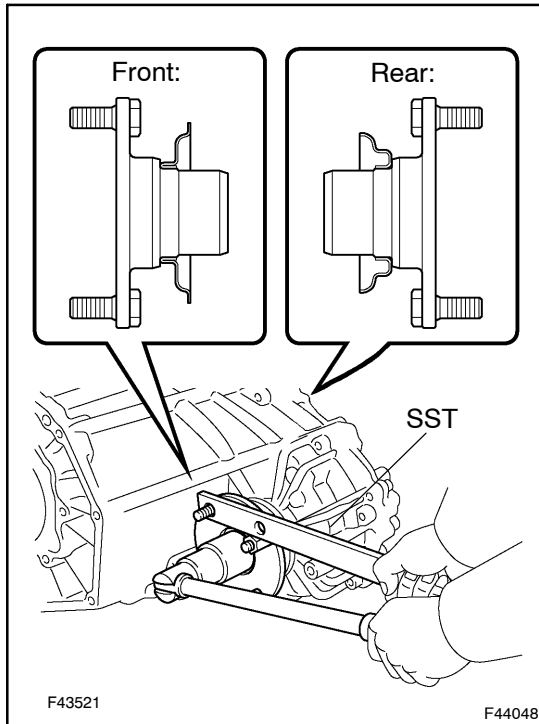

127. INSTALL OUTPUT SHAFT COMPANION FLANGE SUB-ASSY

- (a) Install the companion flange sub-assy to the drive sprocket sub-assy. (front)
 (b) Using SST to hold the companion flange, install a new companion flange lock nut.

SST 09330-00021

Torque: 118 N·m (1,200 kgf·cm, 87 ft·lbf)

- (c) Using a chisel and hammer, stake the companion flange lock nut.

128. INSTALL OUTPUT SHAFT COMPANION FLANGE SUB-ASSY

- (a) Using SST, install the companion flange sub-assy (rear) in the same way as the companion flange sub-assy. (front).

SST 09330-00021

Torque: 118 N·m (1,200 kgf·cm, 87 ft·lbf)

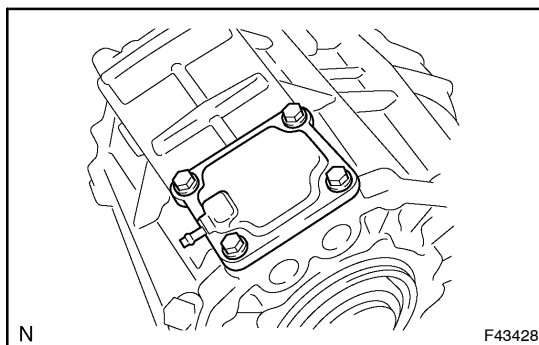

129. INSTALL BREATHER OIL DEFLECTOR

130. INSTALL TRANSFER CASE COVER SUB-ASSY

- (a) Install the case cover sub-assy with the 4 bolts.

Torque: 18 N·m (184 kgf·cm, 13 ft·lbf)

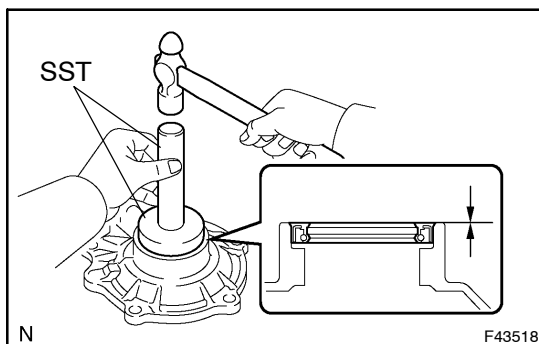

131. INSTALL TRANSFER COVER TYPE T OIL SEAL

- (a) Using SST and a hammer, drive in a new oil seal until its surface is flush with the retainer upper surface.

- (b) Coat the lip of the oil seal with MP grease.

SST 09950-60010 (09951-00590), 09950-70010 (09951-07100)

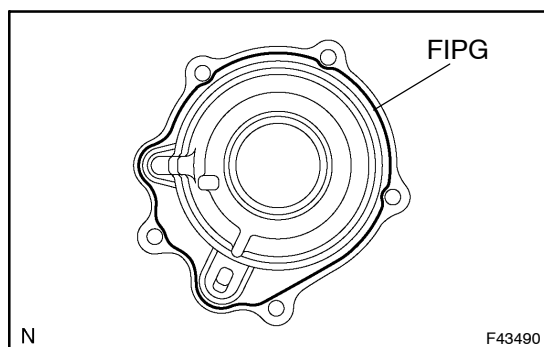

132. INSTALL TRANSFER RH BEARING RETAINER SUB-ASSY

- (a) Apply FIPG to the bearing retainer sub-assy, as shown.

FIPG:

Part No. 08826-00090, THREE BOND 1281 or equivalent

- (b) Apply sealant to the bolt thread.

Sealant:

Part No. 08833-00080, THREE BOND 1344, LOCTITE 242 or equivalent

- (c) Install the bearing retainer sub-assy with the 5 bolts.

Torque: 12 N·m (117 kgf·cm, 8 ft·lbf)

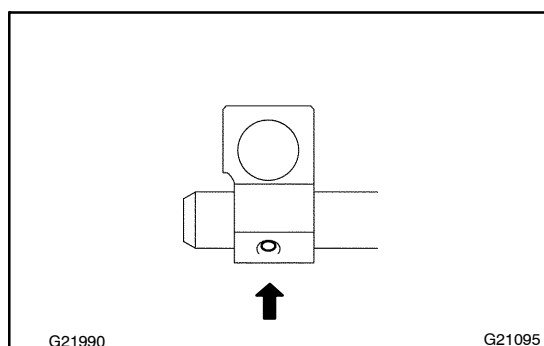
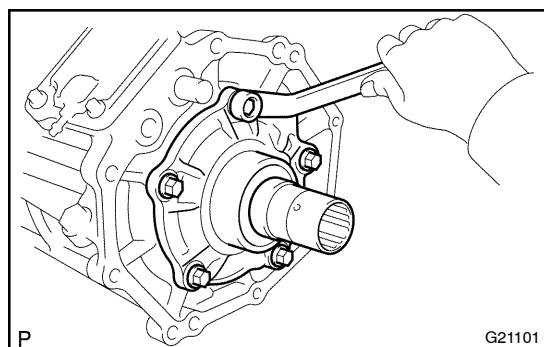

133. INSTALL TRANSFER GEAR SHIFT HEAD NO.2

- (a) Using a pin punch and hammer, install the slotted pin to the gear shift head No.2.

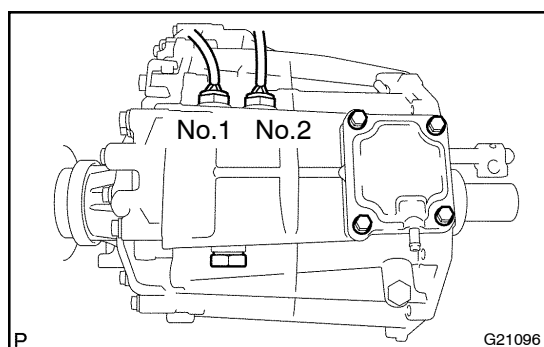

134. INSTALL SWITCH

- (a) Install a new gaskets, the indicator switches and the case No.1 plug.

Torque: 37 N·m (377 kgf·cm, 27 ft·lbf)

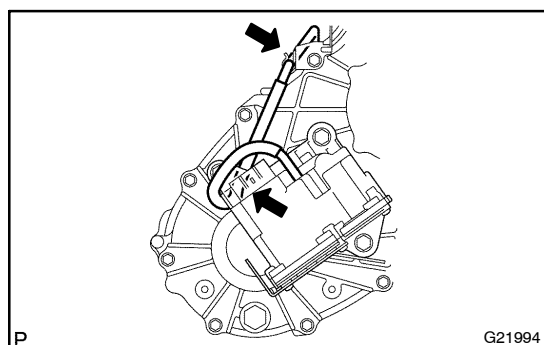

135. INSTALL HOSES

NOTICE:

- Place the hose that passes between the transfer rear case and the actuator motor.
- Adjust the clamp position to prevent the excessive bent or expansion/contraction of the hose.

136. INSTALL TRANSFER ASSY

- (a) Install the transfer to the automatic transmission.
- (b) Install the 2 clamps and 8 bolts.

Torque: 24 N·m (245 kgf·cm, 17 ft·lbf)

137. INSTALL AUTOMATIC TRANSMISSION ASSY

- (a) 2UZ-FE : (See page [40-7](#))

138. INSTALL TRANSFER CASE LOWER PROTECTOR

- (a) Install the 4 bolts with the transfer case lower protector.

Torque: 18 N·m (184 kgf·cm, 13 ft·lbf)

139. ADD TRANSFER OIL (See page [31-3](#))